

**CETOP RP 53P-43P
PNEUMATIC CYLINDERS
PNS SERIES Ø32 - Ø100**





PNS SERIES

CETOP RP 43P - Ø32 - Ø100

CUSHIONING CYLINDER
WITH STEEL TUBE

PNS IS ALSO AVAILABLE WITH HIGH
TEMPERATURE ENDURANCE SEALS
AND THE FAVORITE REQUIRE IN THE
MARKET SINCE 25 YEARS



PNS: DOUBLE ACTING CYLINDER

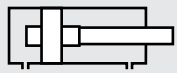

PNS-Y: DOUBLE ACTING CYLINDER
WITH CUSHIONING

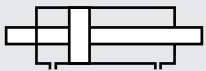

PNS-D: DOUBLE ACTING CYLINDER
WITH DOUBLE ROD

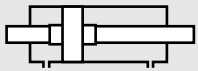

PNS-YD: DOUBLE ACTING CYLINDER
WITH CUSHIONING AND DOUBLE ROD

Example of order:

<u>PNS-Y</u>	<u>032-0100</u>	<u>FM</u>	<u>K4</u>
Product Code	Cylinder Ø Stroke	Cylinder Mountings	Variants from Standard System

VARIANTS FROM STANDARD SYSTEM:

- R1: Stainless Steel Piston Rod (SS 304-SS 316)
- R4: Stainless Steel Nut for Piston Rod (SS 304)
- M1: Extended male Piston Rod Thread
- M2: Female Piston Rod Thread
- M3: Special Piston Rod Thread
- M4: Extended Piston Rod
- K1: Seals for Max. 150°C (Viton)
- K2: Piston Rod Seal NBR + PA
- K3: Seals NBR
- K4: Piston Rod Seal Viton

Force:

Cylinder Ø mm	Rod Ø mm	Thrust and traction forces (6 Bar)	
		Thrust Force (N)	Traction Force (N)
32	12	482	415
40	16	754	633
50	20	1178	990
63	20	1870	1682
80	25	3016	2721
100	25	4712	4418

Working Fluid:

Filtered and lubricated air

Operating Temperature Range:

NBR+Polyurethane (PU) : (-20°C) - (+80°C)
Viton (FKM) : (-30°C) - (+150°C)

Max. Work Pressure:

10 Bar

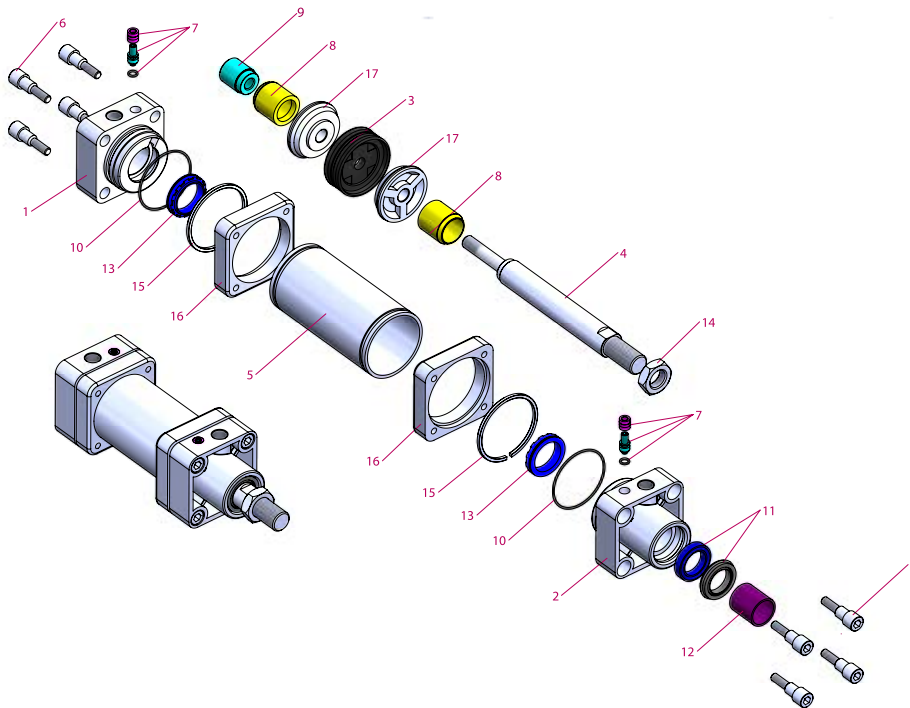
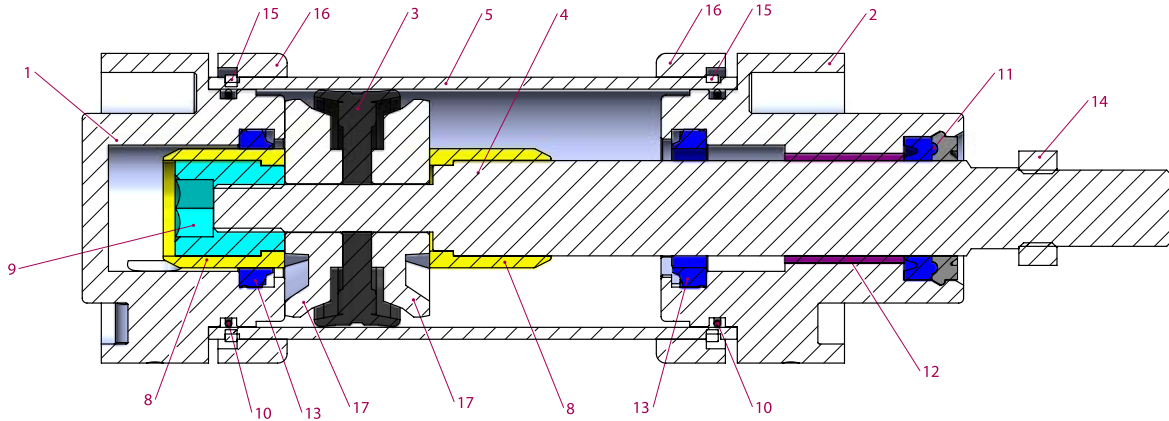

No	MATERIAL NAME	CHARACTERISTIC	PC.
1	Rear Head	Aluminium	1
2	Front Head	Aluminium	1
3	Piston Seal	NBR	1
4	Piston Rod	CK45 Hard Chrome Plated	1
5	Tube	St 52,3 H10 Steel	1
6	Bolt	Galvanized Steel	8
7	Cushioning Screw	Brass+AISI 303 NBR	2
8	Cushioning Plastic	Polyacetal	2
9	Cushioning Fem. Thread	Galvanized Steel	1
10	Head O-ring	NBR	2
11	Rod Seal	HYTREL + PU	1

No	MATERIAL NAME	CHARACTERISTIC	PC.
12	Guiding Bush	CSB-40	1
13	Cushioning Seal	PU	2
14	Nut	Galvanized Steel	1
15	Circle Mounting Ret. Ring	Steel	2
16	Circle Mounting	Aluminium	2
17	Piston Seal Washer	Aluminium	2

Note:

Dia 32: Instead of Cushioning Plastic is used Cushioning yellow and instead of Cushioning Plastic Female Thread is used Cushioning yellow Female Thread. (Material:Brass)

The Piston Seal Washers exist only as Ø32, Ø40, Ø50

The Parts (Nr. 7,8,9,13) don't exist in the Models Without Cushioning. Fibre Nut and Washer exist instead of the Part Nr. 9

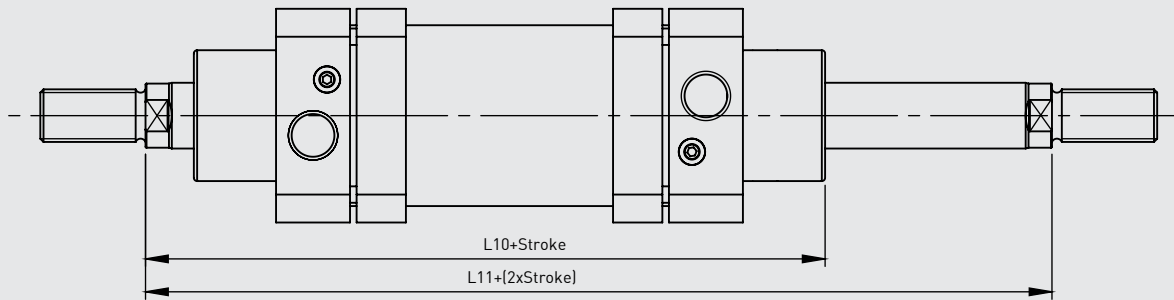
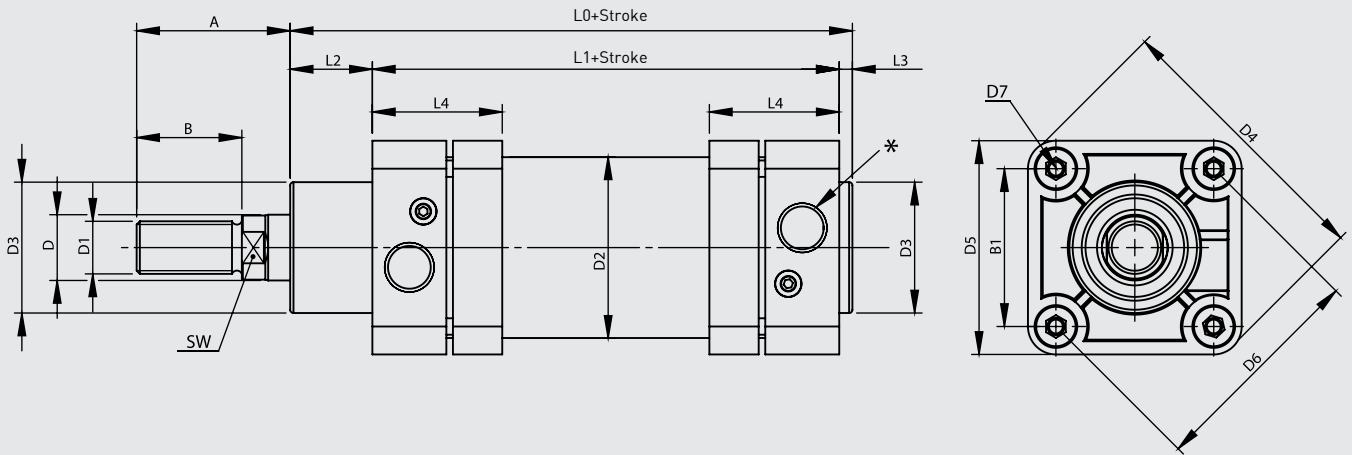

Cylinder Ø mm	A	B	B1	D Ø	D1	D2 Ø	D3 Ø	D4	D5	D6 Ø	D7	L0	L1	L2	L3	L4	L10	L11	SW	*
32	30	20	32,5	12	M10x1.25	36	30	58	45	46	M5	114	94	16	4	40	120	146	10	G1/8"
40	34	24	39,6	16	M12x1.25	45	35	71	54	56	M5	130,5	105	20	4	38	135	165	13	G1/4"
50	44	32	48	20	M16x1.5	55	40	85	65	68	M6	136	106	25	4	40	143	180	17	G1/4"
63	44	32	59,4	20	M16x1.5	68	42	105	80	84	M6	149	115	28	4	46	155	195	17	G3/8"
80	54	40	70,7	25	M20x1.5	86	48	125	96	100	M8	164	124	34	4	50	172	220	22	G3/8"
100	53	40	93,4	25	M20x1.5	107	52	166	126	132	M8	181	134	40	4	56	187	240	22	G1/2"

FLM Flange Mounting

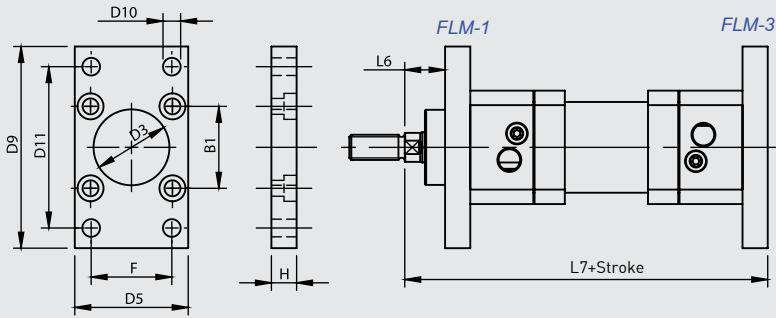

CTM-1 Central Trunnion Mounting

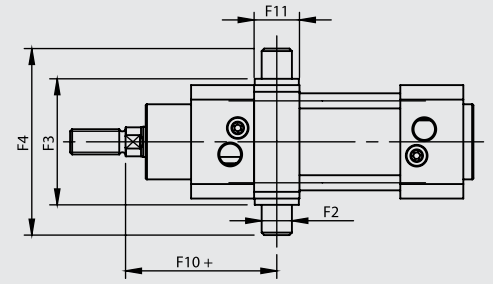

CTM-1 : Fixed Connection

FM Foot Mounting

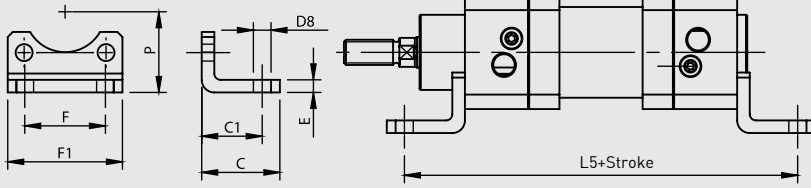

CTM-3 Central Trunnion Mounting

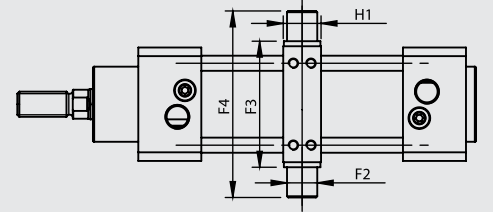

CTM-3 : Adjustable Connection

SF Swivel Flange

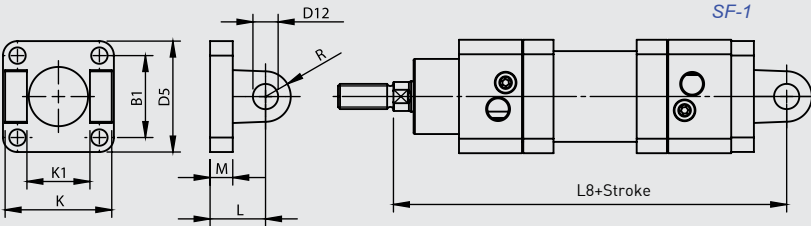

TSM Trunnion Support Mounting

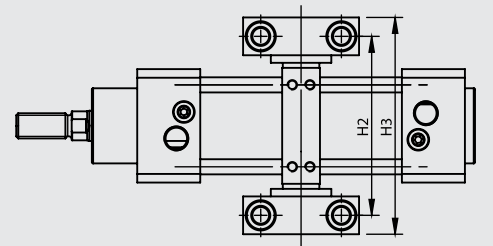

CFM Clevis Foot Mounting

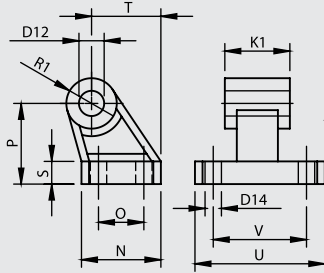

SFWCFM Swivel Flange with Clevis Foot Mounting

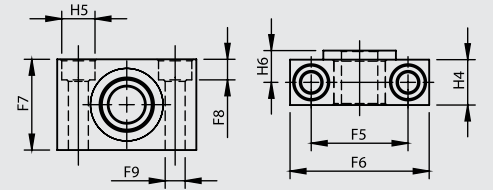
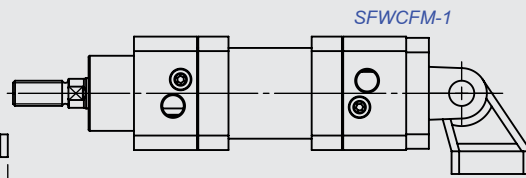

Cylinder Ø mm	B1	C	C1	D3 Ø H11	D5	D8 Ø H14	D9	D10 Ø H13	D11 JS14	D12 Ø H9	D14 Ø H13	E	F	F1 JS14	F2 Ø e9	F3 h14	F4	F5 ±0,2	F6	F7	F8	F9 Ø H13	F10 +	F11
32	32.5	32	24	30	45	7	77	7	64	10	6.6	4	32	45	12	50	74	32	46	30	6.8	6.6	65	21
40	39.6	38	28	35	54	9	90	9	72	12	6.6	5	36	54	16	63	95	36	55	36	9	9	69	24
50	48	42	32	40	65	9	110	9	90	12	9	6	45	65	16	75	107	36	55	36	9	9	79	28
63	59.4	50	35	42	80	9	125	9	100	16	9	6	50	80	20	90	130	42	65	40	11	11	87	28
80	70.7	60	43	48	96	12	154	12	126	16	11	8	63	96	20	110	150	42	65	40	11	11	98	33
100	93.4	57	43	52	126	14	186	14	150	20	11	8	75	126	25	132	182	50	75	50	13	14	108	38

Cylinder Ø mm	H	H1	H2	H3	H4	H5 Ø H13	H6	K h14	K1 H14	L	L5	L6	L7	L8	M	N	O JS14	P JS16	R	R1	S	T	U	V JS14
32	10	15	71	86	15	11	10.5	45	26	22	142	16	130	142	8	31	18	32	10	10	8	27.5	51	38
40	10	20	87	105	18	15	12	52	28	25	161	20	145	160	9	35	22	36	13	11	10	30.5	54	41
50	12	20	99	117	18	15	12	60	32	27	170	25	155	170	11	45	30	45	16	13	12	40.5	65	50
63	15	25	116	136	20	18	13	70	40	35	185	25	170	190	12	50	35	50	18	15	12	44.5	67	52
80	18	25	136	156	20	18	13	90	50	38	210	30	190	210	14	60	40	63	18	15	14	57	86	66
100	18	30	164	189	24.5	20	16	110	60	43	220	35	205	230	15	70	50	71	23	19	15	65	96	76

FLM Flange Mounting

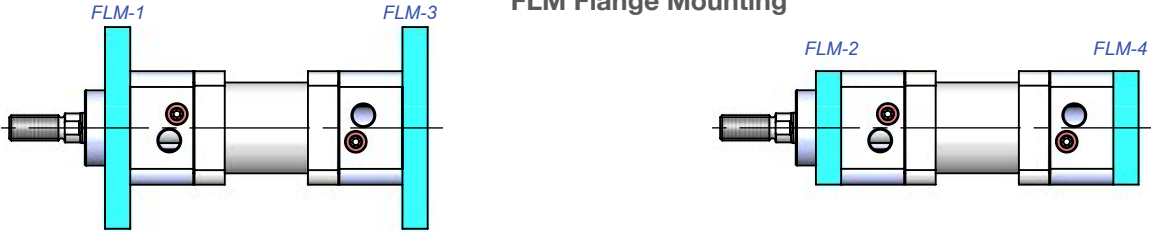

FM Foot Mounting

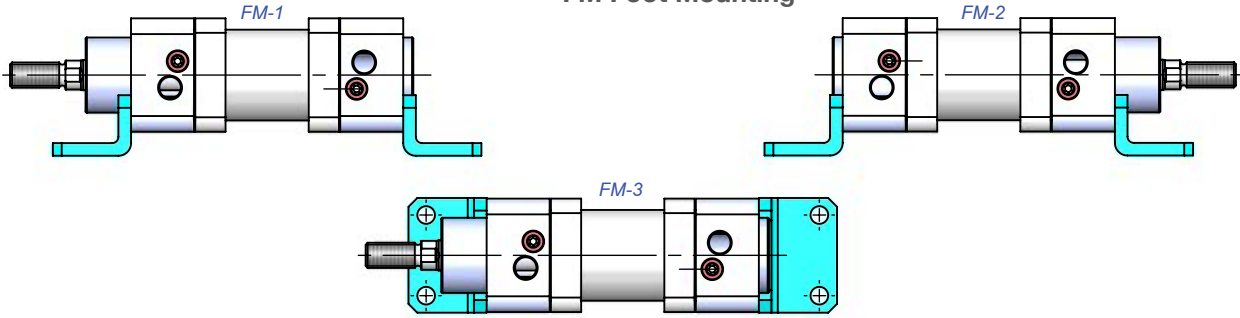

SF Swivel Flange

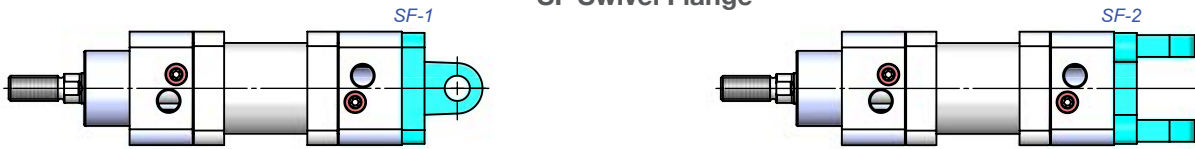

SFWCFM Swivel Flange with Clevis Foot Mounting

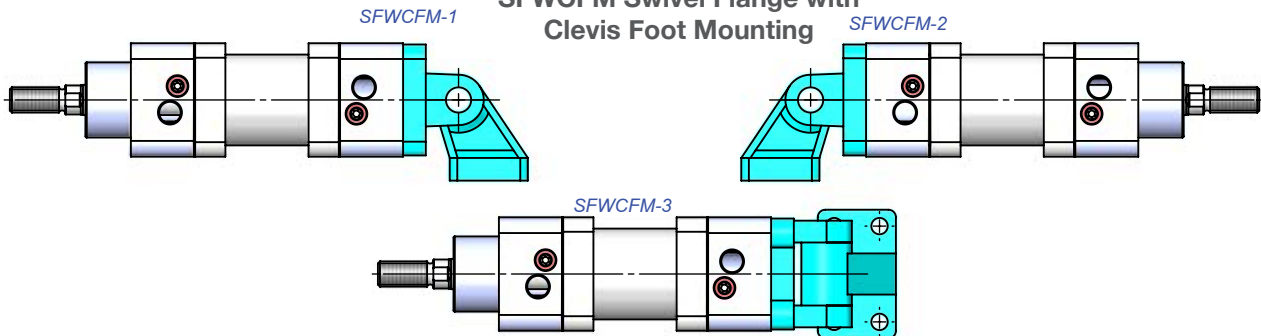

CTM Central Trunnion Mounting

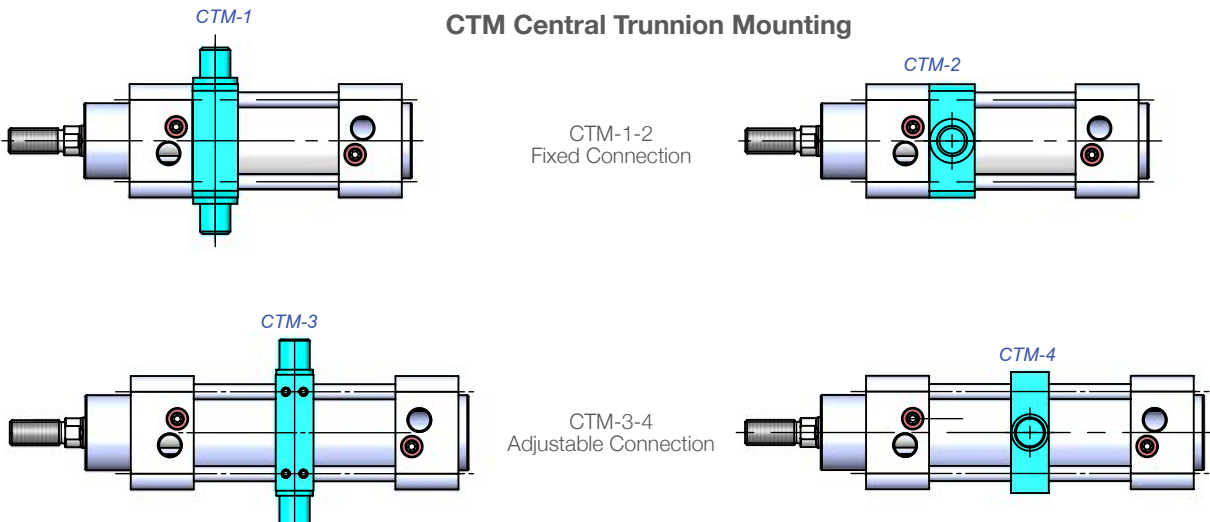

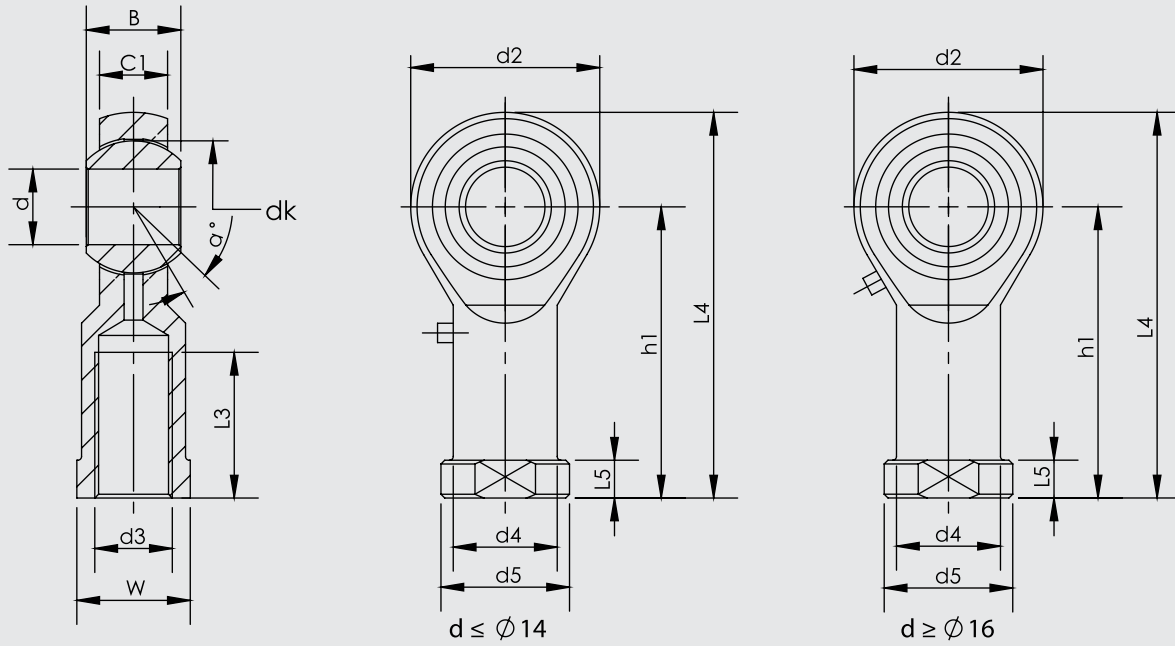

Part No.	Dimensions (mm)													
	d	d3 6H	B	C1	W	L3 min	d2	L4	h1	L5	d4	d5	dk	α°
KMB 10 -1	10	M10x1.25	14	10.5	17	20	26	56	43	6.5	15	19	19.05	13
KMB 12 -1	12	M12x1.25	16	12	19	22	30	65	50	6.5	17.5	22	22.225	13
KMB 16 -1	16	M16x1.5	21	15	22	28	40	84	64	8	22	27	28.575	15
KMB 20	20	M20x1.5	25	18	30	33	50	102	77	10	27.5	34	34.925	14

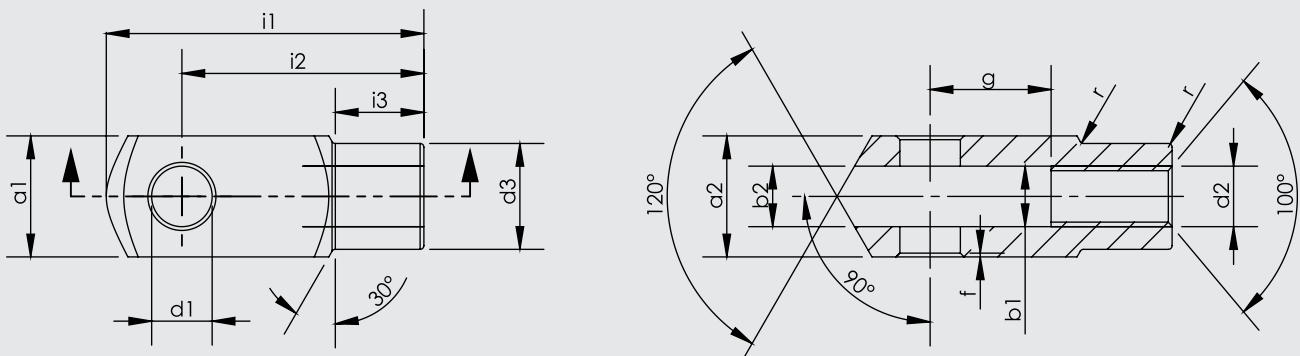

Cylinder ϕ mm	d1 H9	g $\pm 0,5$	a1 h 11	a2 $\pm 0,3$ $-0,16$	b1 B 13	b2	d2 6H	d3 $\pm 0,3$	f $\pm 0,2$	i1 $\pm 0,5$	i2	i3 $\pm 0,2$	r
32	10	20	20	20	10	10	M10x1.25	18	0.5	52	40	15	0.5
40	12	24	24	24	12	12	M12x1.25	20	0.5	62	48	18	0.5
50	16	32	32	32	16	16	M16x1.5	26	1	83	64	24	1
63	16	32	32	32	16	16	M16x1.5	26	1	83	64	24	1
80	20	40	40	40	20	20	M20x1.5	34	1.5	105	80	30	1.5
100	20	40	40	40	20	20	M20x1.5	34	1.5	105	80	30	1.5